

65 & 100 Amp Filter Connector

Two Pole Male Filter & Female Power Connector

ACARA™

Anderson Power Products and Schaffner EMC, leaders in the fields of power interconnect and EMI suppression have partnered to produce the ACARA system of EMI filtered electrical power connectors. ACARA filtered connectors are available in a variety of capacitance values and offers excellent EMI suppression to very high frequencies (6 GHz).

The male filter connector is designed for a fast, error-proof assembly. The female power connector is polarized to the male connector reducing risk of installation error. The optional connector keying further enables the system designer to insure proper site installation.

The ACARA system greatly reduces the number of components and labor required for assembly and installation. The products meet all applicable requirements of UL and EN.

FEATURES

- **Available in a variety of capacitance values**
ACARA capacitor/connector offer excellent EMI suppression to very high frequencies
- **Field disconnect with positive latch**
ACARA mating and un-mating does not require an electrician. The positive latch mechanism keeps connectors mated.
- **Polarized housings with user selective key**
Housings only mate one-way preventing reverse polarity. The user selective key can be used to prevent mating of similar ACARA connectors.
- **Reduces assembly cost and components**
The ACARA system reduces wire preparation and crimping up to 80%



Patents Pending

PRODUCT SPECIFICATIONS

Electrical			Mechanical	
Current Rating UL 1977, UL1283	65 or 100 Amps		Mating Cycles, No Load UL1977	500 cycles
Capacitance	100 to 600 nF		Hot Plug, UL1977 250 cycles	50 amps
Voltage Rating	EN132400	UL 1283	Mating/Unmating Force	30 Lbs (134 N) average
Y2 Capacitors	300 VRMS	250 VRMS	Contact Retention UL 1977	150 Lbs (670 N) minimum
Y4 Capacitors	130 VRMS	130 VRMS	Materials	
Impulse Voltage EN132400	3000 VDC for 2s	1700 VDC for 2s	Insulator & Cable Clamp	PBT UL94V-0
Dielectric Strength	5000 volts		Contacts & Ground Plate	Copper alloy, tin plate
Voltage Drop	<10 millivolts		Capacitor	Wound metallized film
Operating Temperature Range	-25 to 100C			
Ambient Temperature Range	-25 to 60C			

PRODUCT INFORMATION

Male Filtered Connector

Series	Current	Type	Termination	Capacitance & Voltage Class		
AFC	100	-	F	A	/	B0470
065						B0600 for 600 nF class Y4 capacitor
100						B0470 for 470 nF class Y4 capacitor
-						A0220 for 220 nF class Y2 capacitor
Filter						A0100 for 100 nF class Y2 capacitor
A for Bus Bar Termination						
B for Threaded Load Termination						
/						

Female Power Connector

Series	Current	Type	Termination	Wire Size or Length		
AFC	100	-	P	C	/	2 AWG
065						2 AWG for 2 awg crimp barrel
100						4 AWG for 4 awg crimp barrel
-						6 AWG for 6 awg crimp barrel
Power						M35 for 35mm ² crimp barrel
C for Crimp Termination						M25 for 25mm ² crimp barrel
E for Wiring Kit						M16 for 16mm ² crimp barrel
/						020 for 2 awg by 2 meter wiring kit
						030 for 2 awg by 3 meter wiring kit
						050 for 2 awg by 5 meter wiring kit

65 & 100 Amp Filter Connector

Two Pole Male Filter & Female Power Connector

ACARA™

The ACARA male filter connector has a current-carrying conductor passing through the center of each capacitor. This co-axial conductor forms one terminal of the capacitor. The other capacitor terminal is an earthed metal ground-plane which is mounted to the bulkhead plate via the specially designed structural plastic housing and integral EMI gasket. This design feature is common to all ACARA filters and ensures that any radio frequency currents carried on the central conductor are shunted to earth by the capacitor.

Because of the extremely low series inductance resulting from this type of construction, the self-resonant frequency of the ACARA capacitor is very high. Typical frequency response is shown in Figure 1. As frequency increases, the impedance of the feed-through capacitor decreases steadily to provide excellent performance to beyond 6 GHz. Some small resonances can be expected in the performance characteristics of the ACARA capacitor. This is attributable to distributed inductance within the capacitor and can cause its high frequency response to vary slightly from the theoretical.

The ACARA filter connector delivers superior high frequency attenuation, preventing radio frequency emission and protecting sensitive computers, switching and cellular equipment.

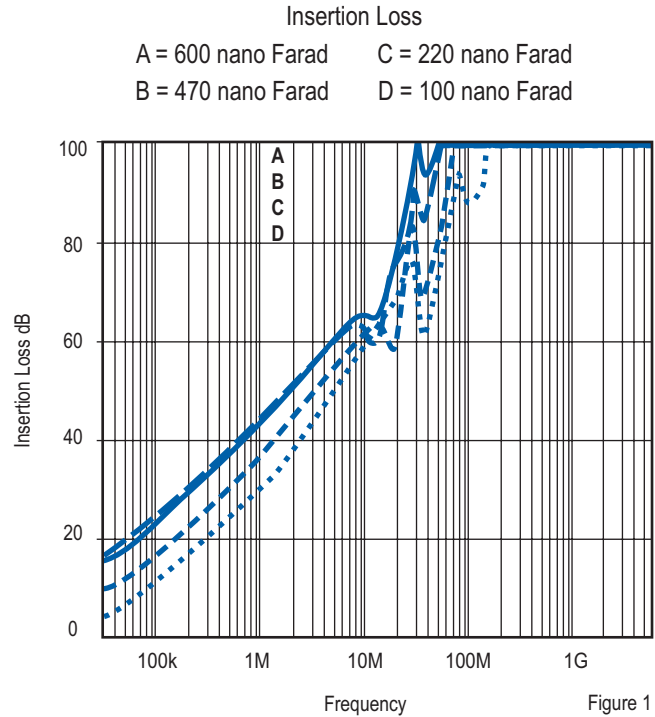

TEMPERATURE CHARTS

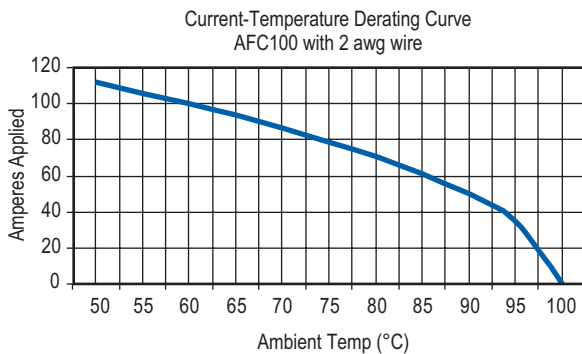
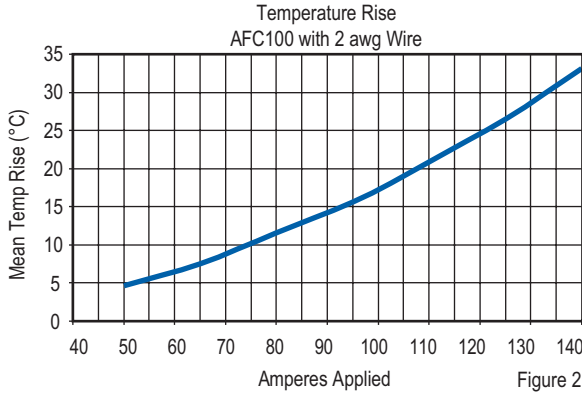

The ACARA female power connector is designed for safety and performance. The plastic housing is polarized to the male filter connector preventing the installer from reversing polarity which can result in injury to the installer and severe damage to the system. By using the optional 6 position key, the system designer can further restrict connector mating to insure that ACARA connectors of different capacitance or operating voltage can not be mated at field installation. The positive latch and wire strain relief of the ACARA power connector further enhance the safety of the system. The wire strain relief acts as a secondary mechanism to insure contact retention and it prevents creep of the wire insulation jacket which can expose bare conductor and result in electrical shock. The positive latch prevents accidental un-mating but allows for immediate power disconnect for emergency service or repair.

The patent pending ACARA socket contact offers superior electrical performance, hot mating (hot plug), low insertion forces and high mating durability. The socket contact is employs a high conductivity copper alloy and a steel spring. This design provides superior conductivity and precise contact forces. The amperage performance of the ACARA connector versus temperature is shown in figure 2. The precise contact forces of the ACARA socket contact delivers low mating forces and excellent mating durability. The two sacrificial arms of the ACARA socket contact enables hot plug and disconnect for emergency service or repair.

The combined safety, electrical and mechanical performance of the ACARA system is unique among electrical power connectors.

65 & 100 Amp Filter Connector

Male Filter Connector

ACARA™

ORDERING INFORMATION

Male Termination - Bus Bar Threaded Termination Bus Bar Contact

Part Number	Part Number	Part Number
AFC065-FA/A0110	AFC065-FB/A0110	2-8486G1
AFC065-FA/A0220	AFC065-FB/A0220	
AFC065-FA/B0470	AFC065-FB/B0470	
AFC065-FA/B0600	AFC065-FB/B0600	
AFC100-FA/A0110	AFC100-FB/A0110	
AFC100-FA/A0220	AFC100-FB/A0220	
AFC100-FA/B0470	AFC100-FB/B0470	
AFC100-FA/B0600	AFC100-FB/B0600	

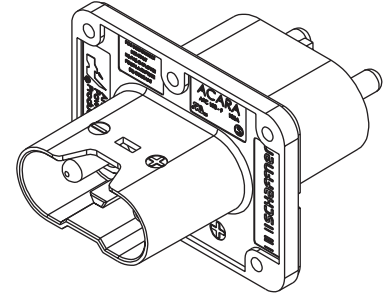

DIMENSIONS

Top View Bus Bar

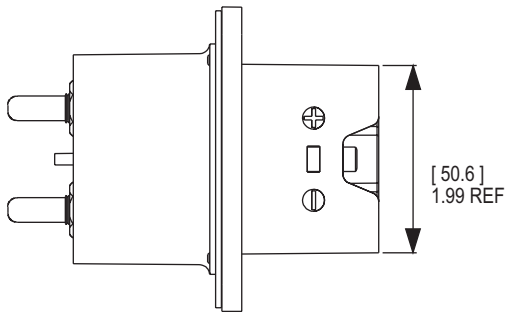

Top View Threaded

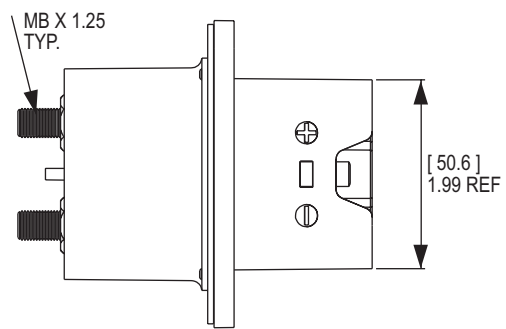

Side View Bus Bar

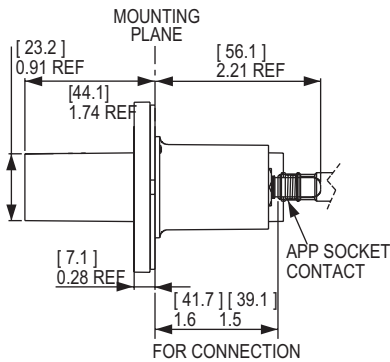

Side View Threaded

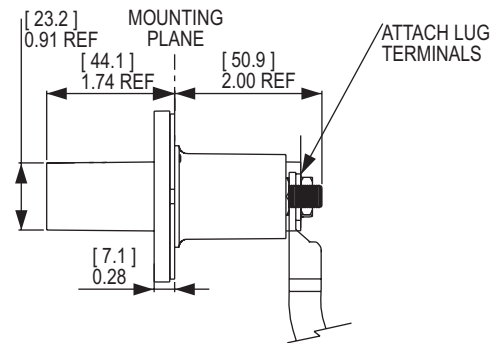

Front View

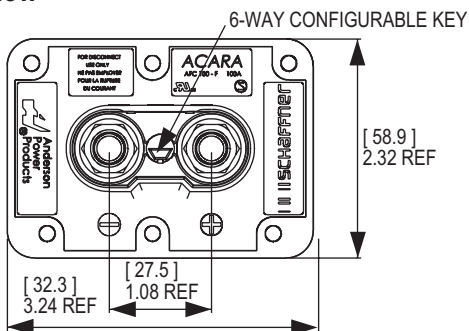

Panel Mounting*

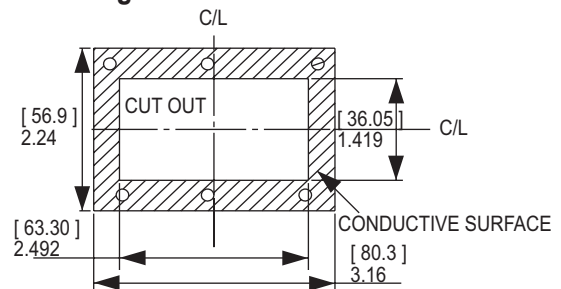

* For detailed dimensions, reference drawing number 3-5846S1 & 3-5846S2

65 & 100 Amp Filter Connector

Female Power Connector

ACARA™

ORDERING INFORMATION

Crimp Termination

Part Number
AFC065-PC/4AWG
AFC065-PC/6AWG
AFC065-PC/M25
AFC065-PC/M16
AFC100-PC/2AWG
AFC100-PC/4AWG
AFC100-PC/M35
AFC100-PC/M25

Pre-wired Termination

Part Number
AFC065-PE/020
AFC065-PE/030
AFC065-PE/050
AFC100-PE/020
AFC100-PE/030
AFC100-PE/050

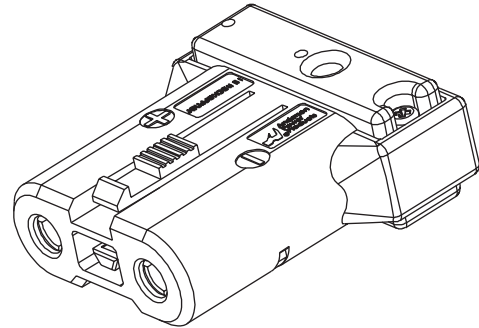

DIMENSIONS

Top View

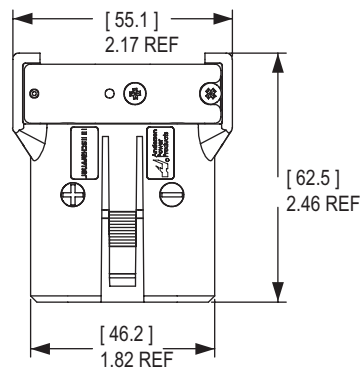

Side View

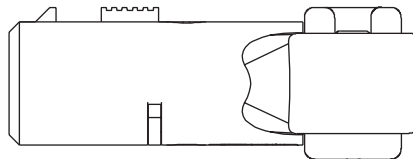

Front View

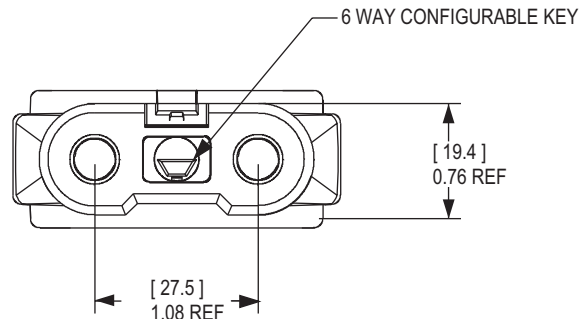

DS-ACARA100 REV01



Anderson Power Products®
13 Pratts Junction Road, P.O. Box 579
Sterling, MA 01564 / USA
T:978-422-3600 F:978-422-3700
www.andersonpower.com



Schaffner EMC Inc.
52 Mayfield Avenue, Edison, New Jersey 08837 / USA
T: +1 732 225 9533 Toll free: 0800 367 5566 F: +1 732 225 4789