

ACARA Filter Connector AFC 065, AFC 100

Ultra-compact high current filter connector for DC and AC applications

SCHAFFNER

safety for electronic systems



- New connector and filter all in one solution
- Excellent EMI suppression to very high frequencies
- Polarized housings with user selective key
- Reduces assembly cost and components

Approvals



ACARA product has several patents pending



By May 2005

Technical specifications

Electrical	
Maximum continuous operating voltage:	Y2, 300VAC (EN132400) / 300VAC (UL1283) Y4, 130VAC (EN132400) / 130VAC (UL1283)
Typical operating voltage:	48VDC
Operating frequency:	dc to 60Hz
Rated currents:	65 to 100A @ 60°C (UL1977/UL1283)
High potential test voltage for capacitors:	Y2, 3000VDC for 2 sec Y4, 1700VDC for 2 sec
Temperature range (operation and storage):	-25°C to +100°C (25/100/21)
Flammability corresponding to:	UL94V-0
Capacitor:	Y2 and Y4 according to EN132400
Mechanical	
Mating cycles, UL1977, EN61984	500 cycles
Hot plug (CBC), UL1977, EN1984	65A
Mating/unmating force	134N (30lbs) average
Contact retention UL1977	670N (150lbs) minimum
Protection category	IP20
Materials	
Insulator & cable clamp	PBT UL94V-0
Contacts & ground plate	Copper alloy, tin plated
Capacitor	Metallized film MKP

Typical electrical schematic

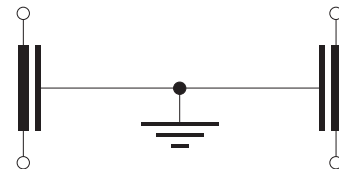

Schaffner EMC the leader in the field of EMI suppression and Anderson Power Products the leader in the field of interconnect have partnered to produce the ACARA EMI filtered power connector system. The ACARA filtered power connector system offers excellent EMI suppression. With the ACARA system you have an easy, safe and removable filtered power connection allowing you to reduce your components, installation and maintenance cost.



Features and benefits

- Integrated feedthrough capacitors with a variety of capacitance values
- High frequency attenuation and EMI suppression up to 10GHz
- Components and installation cost saving
- Reverse polarity protection
- Keying possibility up to 6 connectors
- Easy field disconnect with positive latch
- High current types up to 250A

Typical applications

- 48VDC battery power systems for Telecom Base stations and computer server
- 18V battery back-up power plants for UPS power supplies
- Protecting sensitive computers, switching and cellular equipment
- Preventing radio frequency emission to increase system and information security

Filter/connector selection table

Male filter connector 	Current rating* @ 60°C	Capacity	Capacitor class Y2/Y4 (EN, UL)	Termination**		Weight	Matching female connector***	
	[A]	[nF]		busbar 	threaded 	busbar [kg]	threaded	
AFC 065-F(X)/B0600	65	600	Y4	A	B	0.26	0.3	AFC 065 type
AFC 065-F(X)/B0470	65	470	Y4	A	B	0.26	0.3	AFC 065 type
AFC 065-F(X)/A0220	65	220	Y2	A	B	0.26	0.3	AFC 065 type
AFC 065-F(X)/A0100	65	100	Y2	A	B	0.26	0.3	AFC 065 type
AFC 100-F(X)/B0600	100	600	Y4	A	B	0.26	0.3	AFC 100 type
AFC 100-F(X)/B0470	100	470	Y4	A	B	0.26	0.3	AFC 100 type
AFC 100-F(X)/A0220	100	220	Y2	A	B	0.26	0.3	AFC 100 type
AFC 100-F(X)/A0100	100	100	Y2	A	B	0.26	0.3	AFC 100 type

Female connector 	Current rating* @ 60°C	Termination	Weight	Wire size or length
	[A]		[kg]	
AFC 065-PC/6AWG	65	Crimp	0.08	6 AWG for 6 AWG crimp barrel
AFC 065-PC/M16	65	Crimp	0.08	M16 for 16mm ² crimp barrel
AFC 100-PC/4AWG	100	Crimp	0.08	4 AWG for 4 AWG crimp barrel
AFC 100-PC/M35	100	Crimp	0.08	M35 for 35mm ² crimp barrel
AFC 100-PC/M25	100	Crimp	0.08	M25 for 25mm ² crimp barrel
AFC 065-PE/020	65	Wiring kit	****	020 for 2 AWG by 2 meter wiring kit
AFC 065-PE/030	65	Wiring kit	****	030 for 2 AWG by 3 meter wiring kit
AFC 065-PE/050	65	Wiring kit	****	050 for 2 AWG by 5 meter wiring kit
AFC 100-PE/020	100	Wiring kit	****	020 for 2 AWG by 2 meter wiring kit
AFC 100-PE/030	100	Wiring kit	****	030 for 2 AWG by 3 meter wiring kit
AFC 100-PE/050	100	Wiring kit	****	050 for 2 AWG by 5 meter wiring kit

Busbar contact ordering no. 2-8486G1

- * For higher currents please refer to the AFC 150 and AFC 250 datasheet.
- ** To compile a complete part number, please replace the "(X)" with the required termination A or B.
- *** Please select the matching female connector from the list below.
- **** Weight depends on the kind of wire specified.

Typical filter attenuation

The ACARA connector has a current-carrying conductor passing through the center of the capacitor. This co-axial conductor is one terminal of the capacitor. The other terminal is the metal outer casing of the capacitor, which was specifically designed for being attached to a grounded metal bulkhead. This design is common to all ACARA filters and ensures that any radio frequency currents carried on the central conductor are shunted to earth by the capacitor.

Because of the extremely low series inductance resulting from this type of construction, the self-resonant frequency of an ACARA capacitor will be very high. A typical frequency response is shown below. As frequency increases, the impedance of the feedthrough capacitor decreases continuously to provide excellent performance to beyond 10GHz. Some small resonances can be expected in the performance characteristics of ACARA capacitors as shown below. These are usually attributable to distributed inductance within the capacitor

and can cause its high frequency response to vary slightly from the theoretical.

The ACARA filtered connector shows excellent performance filtering high frequency noise on the line, protecting computer systems, base stations and other electronic systems.

The combination of connector and filter results in an effective solution to simplify the contacting concept.

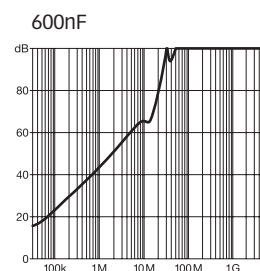
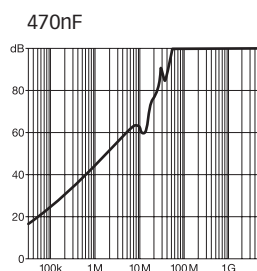
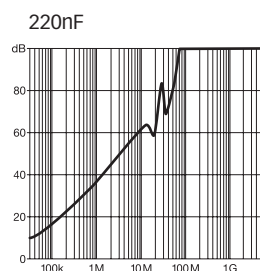
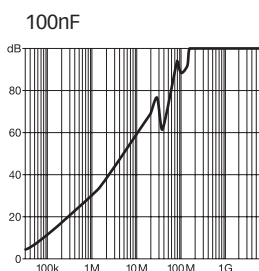

Temperature charts

AFC 100, 2 AWG wire

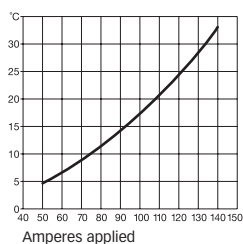

AFC 100, 2 AWG wire

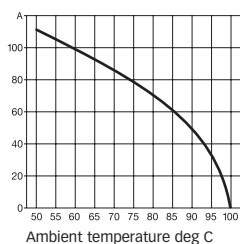

The success of ACARA depends on a very low contact resistance, and this design provides a very high quality material and a clever metal-ization process so there is no risk of over-heating effects. The Hot-pluggable connector has very low arcing between the male and female connector. ACARA is designed for 500 connect/disconnect cycles and 250 cycles under nominal load according UL1977 and EN 60984 giving optimum performance and flexibility. Servers, base stations, and telecom equipment

can easily be connected and disconnected.

The material used in the contact and the mechanical construction of ACARA are important to reach the service conditions of the customer application. The diagrams above show a typical temperature rise of a 100A connector.

The contact resistance of the connector is most important. For example with 100A nominal load, the temperature rise of the contact is only approximately 17°C.

The patented ACARA connector family offers fast easy connecting and a long lifetime with hundreds of connect/disconnect cycles. To achieve this high conductivity copper is used which gives a low temperature rise. The copper material has good spring properties at contact interface and with good formability for crimping to finely stranded copper conductors. The spring system provides high mechanical shock/vibration stability with no contact bounce.

Mechanical data

Panel cut out

	A	B	C	D	E	F	G	H
AFC 065	80.3	69.2	63.3	60.8	36.1	56.9	4.6	2.1
AFC 100	80.3	69.2	63.3	60.8	36.1	56.9	4.6	2.1

All dimensions in mm; 1 inch = 25.4mm
Tolerances according: ISO2768 / EN22768

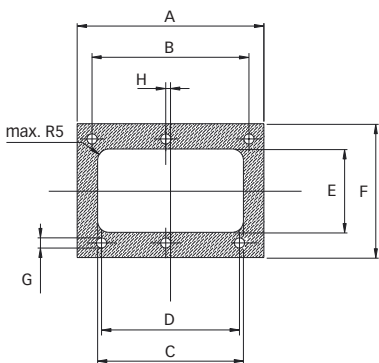

Metall surface/non painted

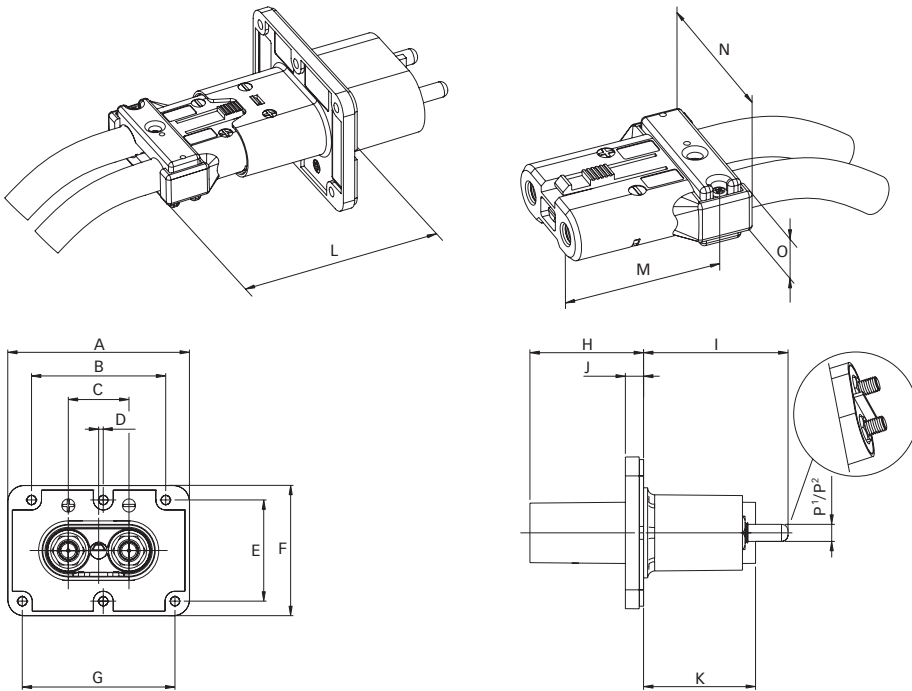

Connector dimensions

	A	B	C	D	E	F	G	H	I	K	L	M	N	O	P ¹	P ²
AFC 065	82.3	60.8	27.5	2.1	45.8	59	69.2	44.1	56.1	43.5	83.2	62.5	55.1	15.2	M8	6.6
AFC 100	82.3	60.8	27.5	2.1	45.8	59	69.2	44.1	56.1	43.5	83.2	62.5	55.1	15.2	M8	6.6

All dimensions in mm; 1 inch = 25.4mm
Tolerances according: ISO2768 / EN22768

- ¹ Threaded
- ² Busbar

Important

The influence of a good earth contact is very important. The overall performance of the ACARA filter is reduced if there is a small resistance between the connector ground and chassis ground. The filter connector is con-

nected with the chassis via a special electric conductive gasket pre-assembled to the connector. The gasket ensures low resistance contact between the filter and the conductive cut-out panel. The region where the gasket is

connected to the chassis ground should not be painted or otherwise isolated. The resistance has to be as low as possible.

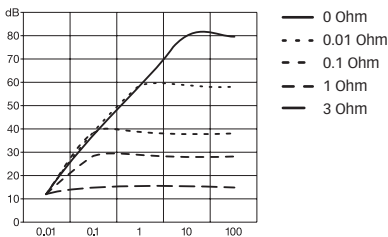

In the diagram you will find the influence between the resistance to ground and insertion

loss. This part of the installation is extremely important for the filter performance.

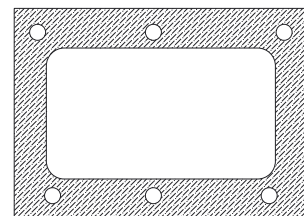

Metall surface/non painted